

Sanitary Centrifugal Pumps

W+ SERIES



W+ Series Sanitary Centrifugal Pumps

PRODUCT FEATURES AND BENEFITS:

- Reliable and Heavy Duty Design
- Energy Efficient
- Quiet Performance with Minimal Vibration
- Superior Shaft Seal Design
- High Pressure Capability
- 3-A (Optional) and EHEDG Certified
- Designed for CIP (Cleaning In Place) as well as SIP (Sterilizing In Place)
- Suitable for a Wide Variety of Products
- Wide Range of Optional Features Available
- Easy and Cost Effective Maintenance



DESIGNED FOR EFFICIENCY:

The W+ pump series is based on a unique hydraulic design that ensures maximum efficiency, allows for highest hygienic standards and reduces noise and vibration.

- **Item 1** - Unique APV spiral volute positioned in the backplate of the pump ensures a direct transfer of liquid from inlet to outlet
- **Item 2** - Advanced, high efficiency impeller design
- **Item 3** - Extended outlets smooth transition to process piping while reducing turbulence and preventing product build-up
- **Item 4** - Heavy walled pump casing ensures that efficiency levels are maintained even at high pressure



Based in Charlotte, North Carolina, SPX Corporation (NYSE: SPW) is a global Fortune 500 multi-industry manufacturing leader. The company's highly-specialized, engineered products and technologies serve customers in three primary strategic growth markets: infrastructure, process solutions, and diagnostic systems. Many of SPX's innovative solutions are playing a role in helping to meet rising global demand, particularly in emerging markets, for electricity, processed foods and beverages and vehicle services. The company's products include thermal heat transfer equipment for power plants; power transformers for utility companies; process equipment for the food & beverage industry; and diagnostic tools and equipment for the vehicle service industry. For more information, please visit www.spx.com.

Engineering excellence, allied to stringent quality control, ensures that SPX's unrivalled range of APV products complies with the highest international standards for hygiene. In the light of growing pressure worldwide to deliver safe, high quality food, all SPX products are designed for easy cleanability, while minimizing the use of valuable resources, such as energy. The APV product portfolio includes a wide range of pumps, valves, heat exchangers, mixers and homogenisers designed for use in the food, dairy and brewing industries, as well as in chemical, healthcare, pharmaceutical processing and heavy industries.

SEALING AREA DESIGNED FOR HYGIENIC

APPLICATIONS:

The shaft seal area is essential in terms of hygiene. W+ pumps are designed without dead pockets and for frequent exchange of liquid. The pumps are equipped with a shaft seal that is ideal for hygienic applications.

SEAL ADVANTAGES:

- Internal seal design optimizes cooling and lubrication of seal surfaces while the seal chamber is built to efficiently dissipate heat. Both work to reduce risk of "dry-running"
- Directed flow assures thorough cleaning of seal area
- The stationary spring is located outside the product contact area to maintain cleanliness
- Two sizes cover all models (excl. W+50/600)
- Front loading seal simplifies maintenance: only the pump housing and impeller have to be disassembled, then the shaft seal can be replaced quickly from the front
- Can easily be rebuilt into a double mechanical shaft seal for use with water flushing or with a barrier medium for aseptic applications
- Double mechanical is mirror image of single: same seal faces and O-rings

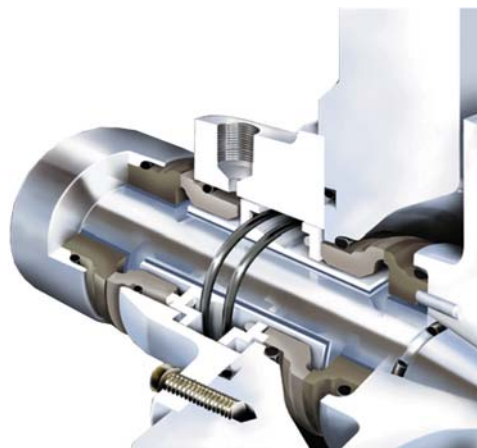
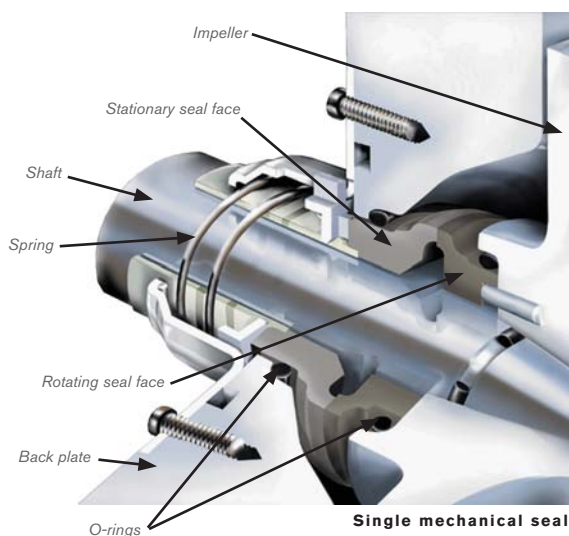

Typical Product Applications

BEVERAGE

- Beer
- Cider
- Fruit Drinks
- Liquid Sugar and Glucose
- Soft drinks
- Wine
- Wort



FOOD

- Animal oils
- Flavourings
- Pet food
- Soups & Sauces
- Vegetable juice
- Vegetable oils
- Vinegars



DAIRY

- Cream
- Milk
- Milk concentrate
- Raw milk
- Skimmed milk
- Whey
- Whey concentrate



PHARMACEUTICAL AND TOILETRIES

- Emulsions
- Extracts
- Lotions
- Perfumes
- WFI (Water for Injection)
- High Purity Water
- Pure water

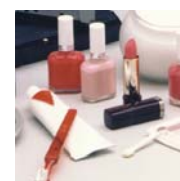

CHEMICAL

- Additives
- Adhesives
- Coatings
- Contaminated liquids
- Detergents
- Emulsions
- Paint



PRODUCT SPECIFICATIONS:

MATERIALS	
CASING	SS 316L
IMPELLER	SS 316L
IMPELLER NUT	SS 316L
INDUCER (WI+)	SS 316L
BACK PLATE	SS 316L
SHAFT	SS 316L
CLAMP RING	SS 304
EXTENSION FRAME	SS 304
LEGS	SS 304
MOTOR SHROUD	SS 304
SHAFT SEAL	CARBON/SILICON CARBIDE OPTIONAL: SILICON CARBIDE/SILICON CARBIDE
ELASTOMERS	EPDM (FDA COMPLIANT) OPTIONAL: FPM, FEP ENCAPSULATED FPM

TECHNICAL DATA	
MAX. DISCHARGE PRESSURE	18 BAR: W+10/8, W+22/20, W+30/80, W+35/55, W+35/35, W+110/130 14 BAR: W+25/210, W+30/120, W+50/8, W+55/35, W+55/60, W+60/110, W+65/350, W+70/40, W+80/80 OPTIONAL: HEAVY DUTY CLAMPING RING, INCREASING MAX. OUTLET PRESSURE TO 25 BAR: W+30/120, W+55/35, W+55/60, W+60/110, W+70/40 20 BAR: W+80/80
MAX. OPERATING TEMPERATURE	95°C AS STANDARD. >95°C, PLEASE CONTACT SPX FLOW TECHNOLOGY
CONNECTIONS	
W+ PUMPS CAN BE SUPPLIED WITH ALL STANDARD THREADS AND CLAMPS IN ACCORDANCE TO DS, BS, DIN, SMS AND ISO AS WELL AS DIN FLANGES.	
MOTOR	
IEC METRIC STANDARD, 2, 4 OR 6 POLES, AT 50/60 HZ, IP55, INSULATION CLASS F. W+ PUMPS ARE AS STANDARD IN EUROPE DELIVERED WITH MOTORS MEETING THE IE2 EFFICIENCY LEVEL IN ACCORDANCE TO THE DIRECTIVE 2005/32/EC ECO-DESIGN OF ENERGY USING PRODUCTS.	
W+ PUMPS MEET THE REQUIREMENTS OF THE REGULATION (EC) NO 1935/2004 ON MATERIALS AND ARTICLES INTENDED TO COME INTO CONTACT WITH FOOD AND REPEALING DIRECTIVES 80/590/EEC AND 89/109/EEC.	

MODEL	INLET SIZE MM	OUTLET SIZE MM	MAX. IMPELLER MM	MAX. CAPACITY (M3/H)		MAX. HEAD (MWC)	
				1450 RPM	2900 RPM	1450 RPM	2900 RPM
10/8	38	25	110	7	13	3	13
22/20	51	51	142	16	33	7	28
25/210	152	102	290	300	-	28	-
30/80	102	76	170	75	150	9	35
30/120	102	76	175	77	155	10	36
35/35	65	51	175	26	53	10	41
35/55	76	65	180	43	87	10	42
50/8	38	25	200	8	18	14	57
50/600	250	200	420	725	-	55	-
55/35	65	38	210	26	53	16	64
55/60	76	51	220	58	115	16	65
60/110	102	76	230	90	170	18	75
65/350	152	102	260	230	475	21	88
70/40	65	38	240	21	44	21	81
80/80	76	51	255	58	115	23	92
110/130	102	76	290	110	225	32	130

A COMPREHENSIVE RANGE:

The W+ range consists of 17 standard models with pressure and flow capacities to 15 bar (50 Hz) and to 725 m³/h (50 Hz) and a number of special versions which may be specifically adapted to customer requirements. The W+ pumps are modular so that any pumping job can be done with a perfectly customized W+ pump.

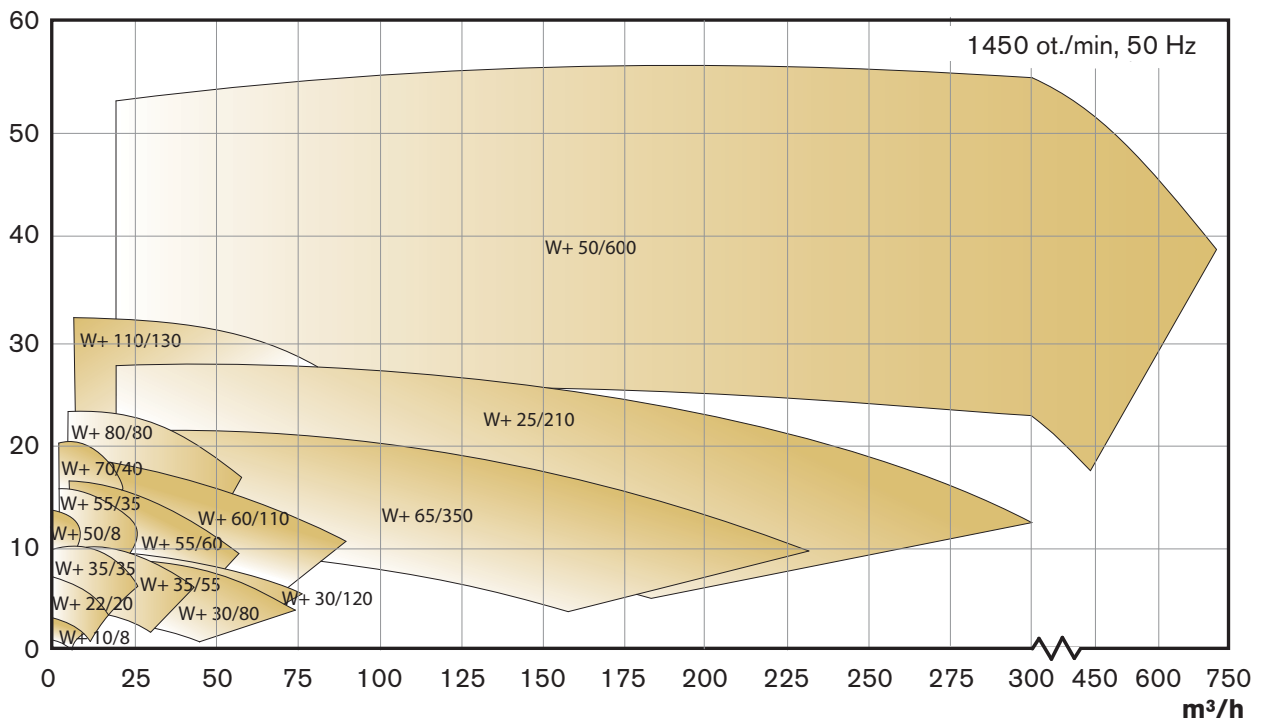
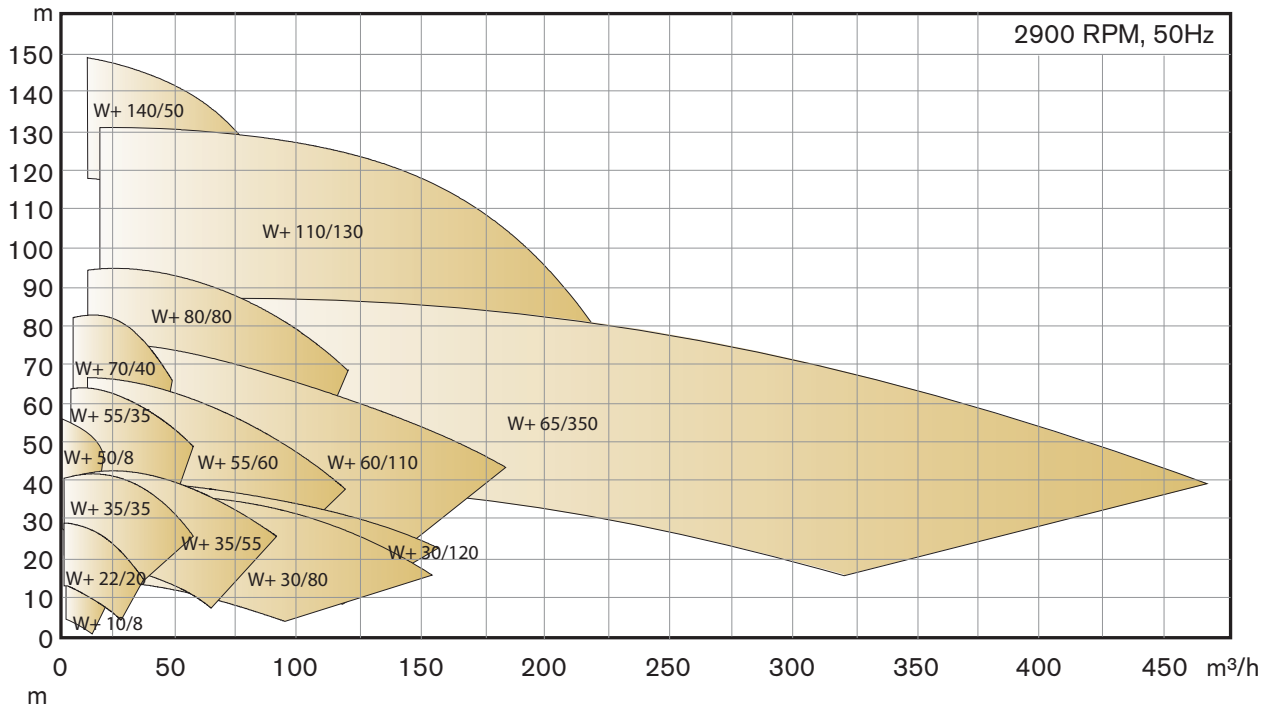

W+50/600



W+80/80



W+35/35

W+ Variations:

WIDE RANGE OF STANDARD OPTIONS AVAILABLE

- Double mechanical shaft seal – Flushed
- Thermal jacket
- Various legs and frame designs
- Stainless steel pump trolley with motor starter
- Special sound-dampened motor shroud
- Pedestal mounted on base plate
- Casing drain (with or without drain valve)
- Back plate with vortex breaker
- Product re-circulation
- ATEX approved design
- Ra < 0.8 µm product contact parts (3-A)
- Ra < 0.5 µm and electro polish product contact parts (without use of castings)
- Documentation package

WI+ INDUCER PUMP

The inducer pump is the alternative to changing the process design when NPSH availability is low. The inducer boosts the inlet pressure, and the risk of cavitation is correspondingly reduced (the NPSH required typically drops by 50-70%). When the risk of cavitation disappears, so does the risk of a large number of operational disturbances that would otherwise result - such as excessive noise, energy loss, product damage and unnecessary wear on the pump. Low suction head is a common “problem” in miscellaneous applications, e.g. when pumping products with low boiling points or in processes that involve vacuums.

13 of the W+ models are available with inducer.

The Wi+ is unique among inducer pumps, since the NPSH requirement is kept to a minimum throughout a large operating range. The inducer further enables the Wi+ pump to handle viscous or gaseous products beyond the range of other centrifugal pumps.



WS+ SELF-PRIMING PUMP

The self-priming Ws+ is designed to handle CIP return and other fluids with entrained air and foam. The unique design reduces the energy consumption and noise of traditional liquid ring pumps by using a high efficiency impeller that can be trimmed to match a specific duty. The Ws+ employs a unique air screw, spinning in an eccentric arranged priming liquid chamber, and a recirculation loop to generate the liquid ring required to handle aerated product and produce a vacuum in the suction pipe.

FEATURES AND BENEFITS:

- Ideal for CIP return
- Extremely clean design
- Superior shaft seal design
- Higher efficiency
- Noise reduction
- Parts interchangeability with W+ centrifugal series
- Particle friendly design
- 3-A (optional) and EHEDG certified
- Designed for CIP (Cleaning In Place) as well as SIP (Sterilizing In Place)



W+ MULTISTAGE PUMP

THE W+140/50 OFFERS THREE SPECIAL FEATURES:

- Provides differential pressures up to 15 bar (50Hz)
- Can be used in processes with system pressures up to 60 bar
- Ensures optimum hygienic standards



And unlike other multistage pumps, it is CIP friendly. It has an open and semi-open impeller, eliminating any hiding place for bacteria. The W+ multistage pump is equipped with a heavy-duty bearing bracket that absorbs all radial and axial forces present in pumps of this kind. Therefore, the W+ 140/50 can use standard motors.

WHP+ HIGH PRESSURE PUMP

The Whp+ is a high-pressure model of the W+ range. The pumps are designed to withstand system pressures up to 60 bar. The Whp+ pump's sturdy construction increases stability and dampens vibrations.



WA+ ASEPTIC PUMP

Environmental requirements are getting stricter and stricter! But today, aseptic production is already essential to certain processes - including the manufacture of long life food and pharmaceutical products. The Wa+ pump is the perfect solution. All seals, including the shaft seal, are designed as double seals.

- Double mechanical shaft seals fitted for sterile flushing
- Double O-ring sealing of pump housing fitted for sterile flushing
- Special aseptic fittings fitted for sterile flushing



Aseptic fitting

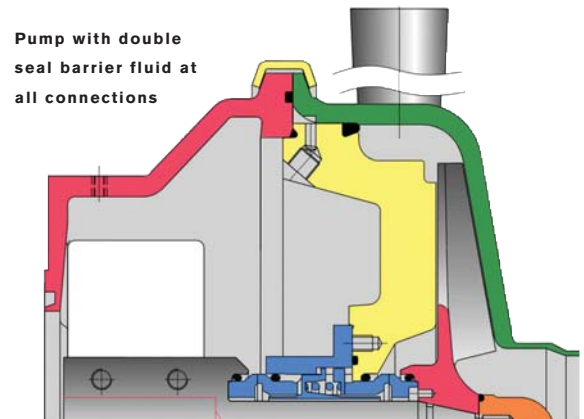

Wa+ pumps ensure absolutely aseptic production processes with barrier media up to 150°C. With a Wa+ pump, the risk of contaminating the product and environment is thus reduced to an absolute minimum.

W+ FOR PHARMACEUTICAL APPLICATIONS LIKE WFI AND HPW

W+ pumps are also available in a pharmaceutical design where product contact parts (Impeller, impeller nut and back plate) are machined from solid 316L SS and electro polished. The deep-drawn casing is polished to Ra < 0,5 µm contact surface finish and electro polished. Other optional features are casing drain, multiple outlet positions and certifications of materials and surface finish.

Sanitary Centrifugal Pumps

W+SERIES



ABOUT SPX

Based in Charlotte, North Carolina, SPX Corporation (NYSE: SPW) is a global Fortune 500 multi-industry manufacturing leader. For more information, please visit www.spx.com

SPX FLOW TECHNOLOGY

Zechenstrasse 49

Unna D-59425

Germany

P: +49 (0) 2303 180 0

F: +49 (0) 2303 180 210

E: apvdeutschland@apv.com

SPX reserves the right to incorporate our latest design and material changes without notice or obligation.

Design features, materials of construction and dimensional data, as described in this bulletin, are provided for your information only and should not be relied upon unless confirmed in writing. Please contact your local sales representative for product availability in your region. For more information visit www.spx.com.

The green ">" is a trademark of SPX Corporation, Inc..